



Low Energy Operator

The Disability Discrimination Act (DDA) is a major driver in the design of today's 'built environment'. Associated best-practice guidance attaches an increasing importance to the use of automatic door operators, low energy operators and power assisted door controls.

These products are essential 'tools' for enabling access to all public buildings - particularly for people with disabilities - and as such are recommended as solutions in satisfying Part M of the Building Regulations for all non-domestic buildings. This, in turn, helps service providers to meet their duties under the DDA.

A comprehensive Design Guide is available to provide specification advice on many aspects of architectural hardware. Please contact our Marketing Department for further information.

The impetus provided by the DDA towards fully inclusive design is undeniable but it is only part of a bigger picture



External doors

External entrance doors to buildings, particularly those used by the general public, need to be convenient for a wide variety of users, e.g. parents with buggies, young children, elderly people, as well as wheelchair users. External swing doors also need to be firmly controlled to resist wind forces and in such circumstances there is a general preference for a powered door solution.



Building Regulations Approved Document M:2004 (ADM04) (England & Wales)

ADM04 gives guidance on the 'considerations' that need to be satisfied in order to gain building control approval. This latest edition states that the maximum acceptable force required to open a door should be no greater than 20 Newtons. This being considered suitable to allow the vast majority of wheelchair users to open a door and conveniently pass through. Although subsequent guidance (see BS 8300) has surfaced since its publication, the principle of achieving much reduced opening forces had been firmly set.

ADM - 2.13 states: "Doors to accessible entrances will satisfy Requirement M1 or M2 if :

- a. where required to be self-closing, a power operated door opening and closing system is used when, through calculation and experience, it appears that it will not be possible otherwise for a person to open the door using a force no greater than 20N at the leading edge".

BS 8300:2001 - Code of Practice. Amendment No.1

The scope of this code (amended early 2005) extends to the opening force requirement first established in ADM. Although the simple ADM 20 Newtons 'rule' technically still exists it has effectively been superseded by a more complex, two-phase (30 / 22.5 Newtons) criteria.

Aside from these 'headline' figures, the guidance in BS 8300 clearly points to the use of powered solutions as a means of achieving a high, and therefore desirable, level of accessibility.

Section 6.3.2 states: " Where the force of the closing device is insufficient to keep an entrance door closed under windy conditions, consideration should be given to installing one of the following door closing systems:

- a. a power operated (automatic) door;
- b. a low energy swing door;
- c. a power operated revolving door arrangement;
- d. an entrance lobby or air lock system of inner and outer doors"

Swing-action entrance doors - which are required to be fully accessible but may not be suited to full automation - are best equipped with power assisted, low-energy operators.

Section 6.3.4 states: "A low energy power operated door operator should be considered for use on swing doors with relatively low levels of pedestrian usage as these doors can either work in manual mode or be set to provide powered opening assistance to users when required."

Dor-O-Matic Low Energy Operator



Dor-O-Matic power assisted units from Ingersoll Rand are designed as a low energy electro-mechanical drive door operator. Being a totally self contained device it offers an exceptionally cost effective means of automating new or existing swing doors to provide ease of access to satisfy the requirements of The Disability Discrimination Act and Building Regulations Part M. It also improves accessibility in general for elderly people and parents with buggies.

The Ingersoll Rand unit is ideally suited to applications where the cost of a full automatic package would be prohibitive, or to retrofit applications where existing joinery details must be retained for design or planning requirements.



The Dor-O-Matic unit is suited to a wide range of applications, not just to provide easy access for disabled people. Its features and operating characteristics can be selected according to its application and by using a selection of auxiliary components the low energy system can be fine tuned to provide a truly versatile solution.

- **Self contained surface mounted unit**
This makes it suitable for either new doors or existing joinery, making it a simple solution for retrofit applications or doors which would otherwise be difficult to automate
- **Powered opening / spring closing**
The opening cycle is power assisted and the closing cycle is under spring power.
In the event of power loss the unit acts as a conventional manual door closer in both modes
- **Universal unit**
Mounted on the head frame, it is suitable for internal or external doors - left or right hand - and for installation on the 'push' or 'pull' side of the door
- **Range of operating modes**
The Dor-O-Matic unit is highly versatile, being site programmable to offer
 - fully automatic operation
 - power assisted / manual operation
 - push-and-go operation
 - fully manual operation

Note: The Dor-O-Matic Series must be fitted in accordance with BS 7036 and should be fitted by an authorised technician.

The features illustrated on the standard Dor-O-Matic operator give precise door control in all conditions. However, provision is made for additional controls including manual or automatic activation, safety sensors and integrated electronic locking



Automatic operation can be achieved using motion detectors (wall or ceiling mounted bi-directional sensor, shown right) or activation pads/plates mounted adjacent to the door (far right)

Electromechanical opening system provides a smooth, low noise operation which has exceptional reliability. An internal mechanical stop reduces wear and tear, protects the surrounding structure and avoids the need for external door stops which present a trip hazard

Extruded aluminium cover has a satin anodised finish as standard and can be painted to customer requirements

Built-in transformer and additional ports ensure the unit is totally self-contained and allows the system to incorporate sensors and integrated locking facilities (electric strikes or electro magnets)

Spring controlled closing action has adjustable closing power to suit site conditions and door size and is fail safe, closing the door in the event of a fire or on power failure

The unit can be used with slide track for mounting on the pull side of the door or with projecting armset for mounting on the push side of the door

Microprocessor controller tracks the door position by controlling the door features at all times. In addition it makes the device easy to adjust, allows for future changes of function and unit set up and allows for additional hardware to be easily added at any time

Additional surface mounted safety sensors can be installed on the either side of the door. The sensor will stop the closing or opening cycle on detection of a person or object in the opening or closing arc of the door. Satin aluminium finish with black end caps



Low Energy Operator Features & Functions



Mains power to the low energy operator can be fed either directly into the back of the unit in the case of hollow metal frames or into the end of the unit in the case of solid frames.

Connection to safety sensors mounted on the door is via surface loops which carry the cables from the door to the frame (as shown above) or from the door directly into the operator.

A series of optional surface mounted satin stainless steel push pads and plates is available to operate the low energy unit from either side of the door.



Dor-O-Matic Features & Functions

- Automatic operation mode allows the opening cycle to be activated by either motion sensor, manually operated push pad/plate or via an integrated access control device such as a card reader or PIN code
- Push & Go allows simple operation without additional activation devices to meet the owner's need for an inexpensive solution. The powered opening cycle is initiated by gently pushing or pulling the door
- Power Boost in the final closing phase ensures the door reaches the fully closed position to provide peace of mind that the door is secure
- Adjustable opening speed ensures a safe and flexible opening cycle to suit different applications
- Delayed action holding inhibits the closing cycle to allow slow moving traffic to pass through
- Safety stop halts the door when someone or something is in the opening or closing arc to reduce the risk of potential accidents
- Emergency egress allows the door to be operated manually in an emergency

Low Energy Operator Toilet Door System

It is stated within Approved Document M:2004 that adequate provision is made to enable all people not only to gain access to a building but also to use the building and its facilities. The Dor-O-Matic WC unit is a direct response to this requirement. We have developed an integrated system which allows the door of a disabled toilet facility to be fully automated. All the components are supplied within the package which can be applied to a newly constructed doorset or to an existing installation.



Ceiling mounted motion sensor monitors if the WC is occupied.



The Dor-O-Matic operator can be supplied for inward or outward opening doors as required. Each low energy unit is interfaced with a special internal and external activation pad, a locking unit and an occupancy sensor.

A special external activation pad mounted adjacent to the door includes LED indicators to signal the locked condition of the door. In a green light mode, pushing the pad from outside will trigger the powered operator to open the door.



The internal activation pad also has built-in LED indicators to show the condition of the door. The red light indicates the door is closed and locked and will simultaneously show red on the external pad.

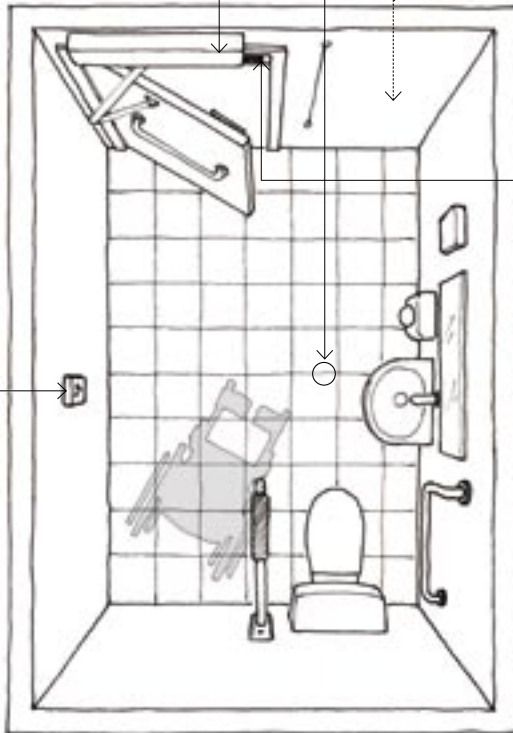

The Dor-O-Matic unit is linked to an electromagnetic lock surface mounted to the underside of the frame, with the armature mounted on the door face. When the door is activated from inside, it initiates the system to 'close and lock' or 'unlock and open'.

How it operates

The door is opened, closed, locked and unlocked using the Operating Pads outside and inside the facility. The indicator LED's show the same condition on both pads, working as a set of traffic lights (see left). A sensor detects the presence of someone in the WC. The door will close but not lock if no presence is detected. If a presence is detected the door will stay open until the internal pad is pressed to close and lock the door.



Special needs support rails with anti slip grip are also available to complete the installation.

Door Status Lights

- **Green Light Condition** - toilet is vacant and the door will open if the push pad is pressed. If nobody enters the toilet the door will re-close after 90 seconds and revert to Green Light Condition.
- **Red Light Condition** - the door is closed & locked and the outer push pad is rendered inactive. Operating the inner push pad will unlock and open the door.
- **Yellow Light Condition** - While the door is open the unit goes to Yellow Light Condition. If the light is on constant the door is about to close and lock, going into Red Light Condition.
- ☀ **Flashing Yellow Light Condition** - If the yellow light is flashing it indicates the door is opening or closing and about to go into Green Light Condition.

Low Energy Operator Specification

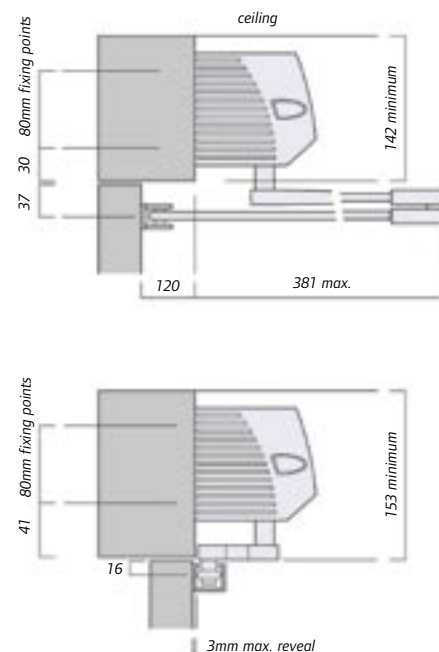
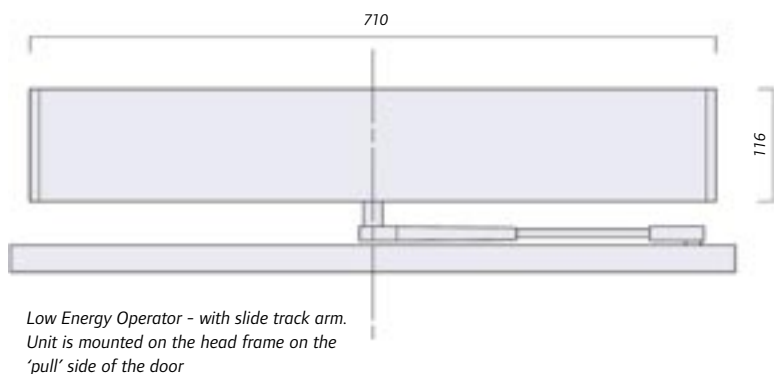
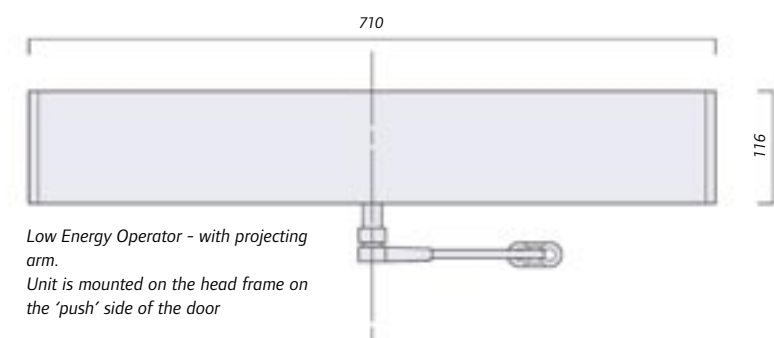

Product Selector

size limits		
max. door width	1200mm	
min. door width *	660mm	
max. door leaf weight	80kg (see glass considerations)	
technical specification		
Power requirements	230/250 volts	
Internal transformer to supply auxiliary hardware	24v AC/DC	
Power supply absorbed	1A average	
Motor drive	48 volts	
Force in opening cycle	40N maximum	
Force in closing cycle	20N maximum	
Operation cycle time with delayed action holding	adjustable from 5 - 60 seconds	
Suitable for fire door applications	up to 2 hrs on approved applications	
features		
standard feature	optional feature	
Adjustable opening speed	●	
Adjustable closing speed	●	
Delayed action holding adjustable 1 - 60 sec.	●	
Push-and-Go facility	selectable on site	
Power boost	●	
Electric locking		●
Auto reverse	●	
Battery backup facility		●
Manual operation on power failure	●	
Barrier rails		●

* Note: minimum door width of 850mm should be allowed for wheelchair use

Glass considerations

In all applications consideration should be given to the overall weight of the leaf in any one package. Standard glazing is considered to be 6.4mm laminated. Any specification above this will be considered to be special and should be calculated accordingly. The maximum weight of a single leaf is 80kg.

6.4mm	17.0 kg per sq metre
7.5mm	19.9 kg per sq metre
8.8mm	23.3 kg per sq metre
10.0mm	26.5 kg per sq metre
12.0mm	32.0 kg per sq metre

General requirements

All notes on drawings applying to a specific installation form part of the overall specification. Ingersoll Rand will provide all labour, materials, equipment and services necessary for the installation of the swing operator.

Work not included

Preparation of the lintel with adequate structural fixing grounds to accept the operator.

Provision of a 240v fused switched spur at the door head. Electrical wiring will be in accordance with standard IEE regulations.

Doors and frames

The unit is suitable for installation on new or existing doors and frames. Doors, frames and side panels supplied by Ingersoll Rand shall be heavy duty interlocked aluminium sections with through-rod bolted construction. All exposed aluminium surfaces shall be in either a painted, satin anodised or stainless steel clad finish.

Rubber finger guards shall be provided with all doors, panels and jambs.

Installation

Ingersoll Rand engineers with a minimum of three years experience are available to provide a full installation service.

Safety and BS 7036

Ingersoll Rand equipment is designed to enable compliance with BS 7036 Code of Practice, which provides guidance on the general safety recommendations applicable to powered pedestrian doors. We can provide project designers and end user recommendations to ensure that installed doors operate safely and correctly in accordance with BS 7036. Ultimate responsibility for conformity however lies with the project designer.



55 Clifton Road • Cambridge CB1 7EF

Telephone 01223 414121 • **Fax** 01223 411002 • **Email** sales@acornironmongery.com

Website www.acornironmongery.com

Whilst Acorn Architectural Ironmongery Limited has taken every care to ensure the accuracy of information, data or advice contained in this literature, no liability in respect of such information or advice, whether given negligently or not, can be accepted by the company. Acorn Architectural Ironmongery Limited retains the right to amend the technical specification of any range of equipment shown without notice.

Produced by Refresh Media Design Limited.